

**MANUAL OF INSTRUCTION  
SEWING MACHINE MODEL 537**

## IMPORTANT

The wires in this mains lead are coloured in accordance with the following code:—

GREEN AND YELLOW - EARTH    BLUE - NEUTRAL    BROWN - LIVE

As the colours of the mains lead of this appliance may not correspond with the coloured markings identifying the terminals in your plug - CONNECT AS FOLLOWS:—

The wire coloured GREEN AND YELLOW must be connected to the terminal marked E or by the earth symbol  $\perp$ , or coloured GREEN or GREEN AND YELLOW

The wire coloured BROWN must be connected to the terminal marked L, or coloured RED

The wire coloured BLUE must be connected to the terminal marked N, or coloured BLACK

If a 13 amp plug is used, fit a 3 amp fuse

For any other plug, protect with a 5 amp fuse or fuse wire

-----

### NOTES

When servicing or changing mechanical parts or lamp bulb the machine must be disconnected from the supply by removing the plug from the socket outlet.

Should it become necessary to replace the lamp bulb at any time, the correct type of bulb must be used, this being SBC type, 240 volts, 15 watt maximum.

WARNING - THIS APPLIANCE MUST BE EARTHED

## CONTENTS

NAMES OF PARTS.....	4	TO START SEWING.....	13
TO REMOVE BOBBIN CASE.....	6	TO REGULATE TENSION OF UPPER THREAD.....	14
TO WIND BOBBIN.....	6	TENSION OF LOWER THREAD.....	15
TO ADJUST BOBBIN WINDING DEVICE.....	8	TO USE BUILT-IN SEWLIGHT.....	15
TO THREAD BOBBIN CASE.....	9	TO ADJUST PRESSURE ON PRESSER FOOT.....	16
TO INSERT BOBBIN CASE INTO THE MACHINE.....	10	TO USE DROP FEED DEVICE.....	16
TO INSERT NEEDLE.....	10	TO REGULATE LENGTH OF STITCH AND DIRECTION OF FEED.....	17
RIGHT NEEDLE AND THREAD FOR RIGHT CLOTH.....	11	STRAIGHT SEWING AND ZIGZAG SEWING.....	18
TO THREAD NEEDLE.....	12	MANUAL ZIGZAG PATTERN SEWING .....	19
TO RAISE LOWER THREAD.....	13		

## NAMES OF PARTS

- |  |                                |
|--|--------------------------------|
| ① Spool pin                                  | ②③ Needle plate                |
| ② Zigzag width control knob                  | ④ Needle                       |
| ③ Top cover                                  | ⑤ Needle clamp                 |
| ④ Top cover thread guide and Tension bracket | ⑥ Thread tension regulator     |
| ⑤ Thread take-up lever                       | ⑦ Arm                          |
| ⑥ Pressure regulator                         | ⑧ Bed plate                    |
| ⑦ Face plate                                 | ⑨ Drop feed knob               |
| ⑧ Thread guides                              | ⑩ Reverse button               |
| ⑨ Presser bar                                | ⑪ Stitch length regulator knob |
| ⑩ Needle bar thread guide                    | ⑫ Stitch indicator window      |
| ⑪ Presser foot thumb screw                   | ⑬ Balance wheel                |
| ⑫ Presser foot                               | ⑭ Bobbin winder latch          |
| ⑬ Shuttle cover slide plate                  | ⑮ Bobbin winder spindle        |
| ⑭ Feed teeth                                 |                                |

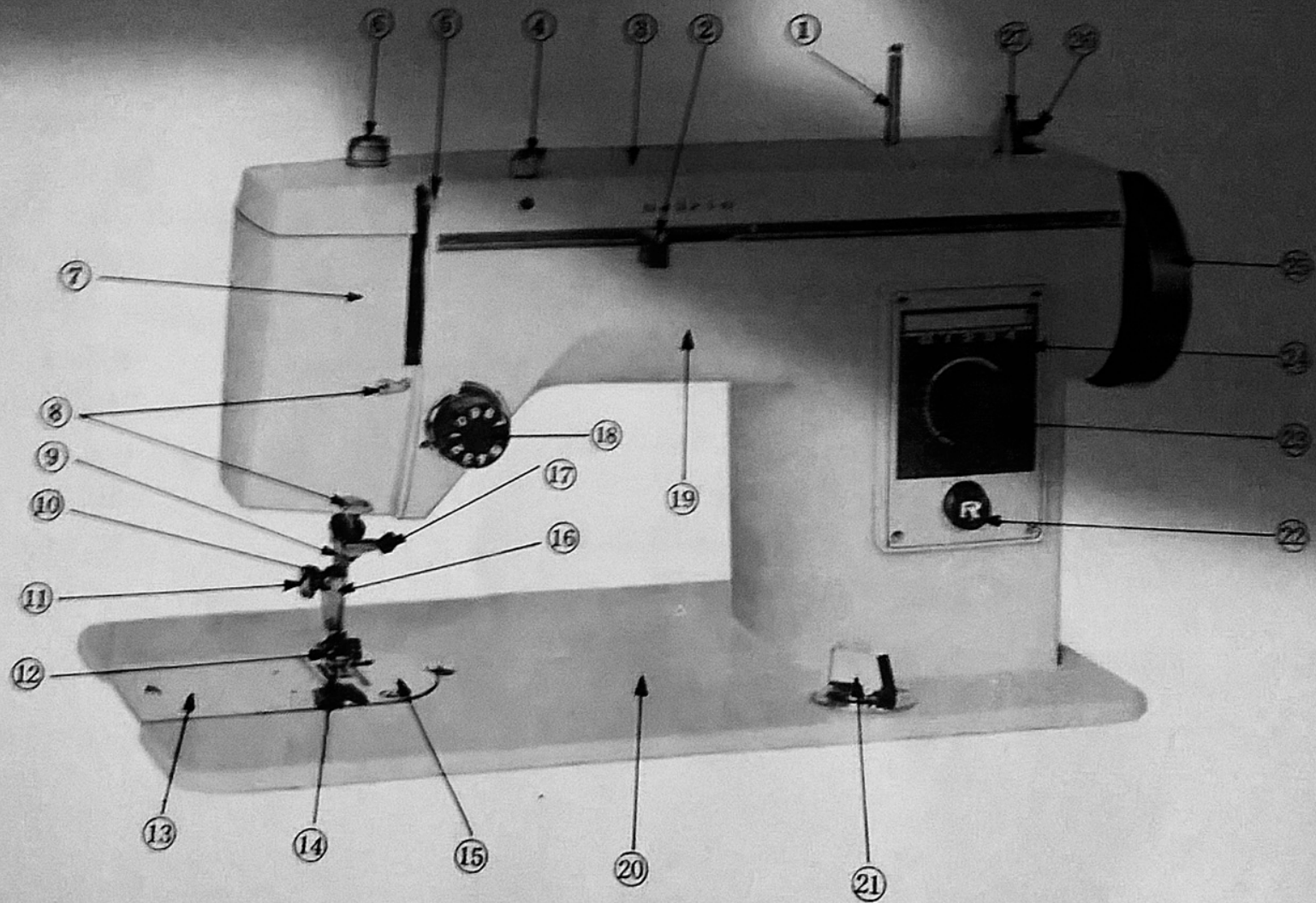

## NAMES OF PARTS

- |  |                                |
|--|--------------------------------|
| ① Spool pin                                  | ⑩ Needle plate                 |
| ② Zigzag width control knob                  | ⑪ Needle                       |
| ③ Top cover                                  | ⑫ Needle clamp                 |
| ④ Top cover thread guide and Tension bracket | ⑬ Thread tension regulator     |
| ⑤ Thread take-up lever                       | ⑭ Arm                          |
| ⑥ Pressure regulator                         | ⑮ Bed plate                    |
| ⑦ Face plate                                 | ⑯ Drop feed knob               |
| ⑧ Thread guides                              | ⑰ Reverse button               |
| ⑨ Presser bar                                | ⑱ Stitch length regulator knob |
| ⑩ Needle bar thread guide                    | ⑲ Stitch indicator window      |
| ⑪ Presser foot thumb screw                   | ⑳ Balance wheel                |
| ⑫ Presser foot                               | ㉑ Bobbin winder latch          |
| ⑬ Shuttle cover slide plate                  | ㉒ Bobbin winder spindle        |
| ⑭ Feed teeth                                 |                                |

### **TO REMOVE BOBBIN CASE**

Turn the balance wheel towards you until the needle bar and take-up lever are both to their highest point.

Open the slide plate in the bed of the machine so that the bobbin case can be reached.

Insert the thumb and forefinger to open the latch and withdraw the bobbin case.

While the latch is held open, the bobbin is retained in the bobbin case and will not drop out.

On releasing the latch and turning the bobbin case downward, the bobbin will drop out.

The bobbin case must never be removed when the needle bar is in the lower position.

Neither should a bent needle be used, as it is liable to damage the bobbin case or the shuttle.

### **TO WIND BOBBIN**

- 1) While holding the balance wheel with your left hand, turn the stop motion screw toward you with the right hand.

This allows the balance wheel to turn freely, disengaging the stitching mechanism.

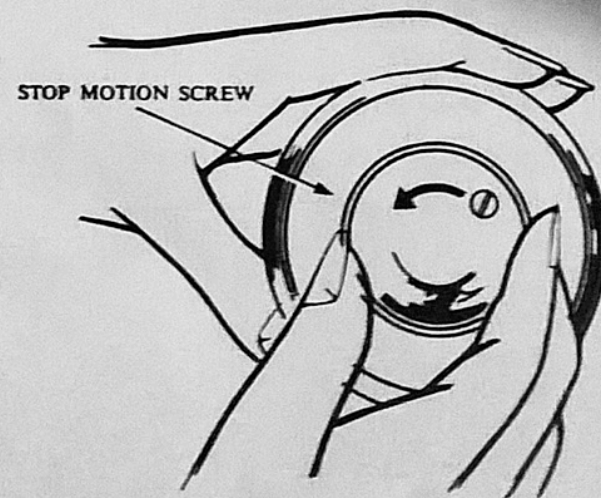
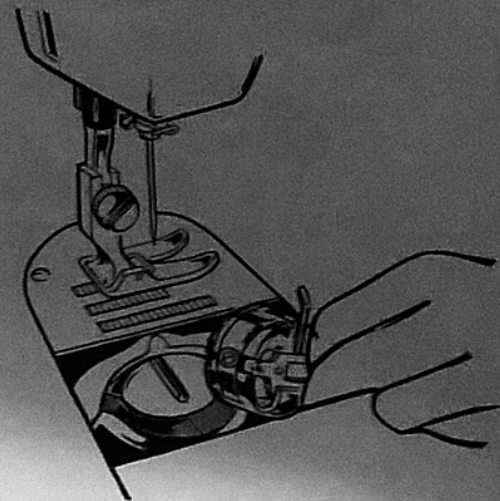

2) Pl  
m  
5)  
3) F  
4) I  
5)  
6)  
7)  
8)  
BOBB  
WIND  
SPIN

- 2) Place a bobbin on the bobbin winder spindle, revolve the bobbin until the notch in the bobbin meets the spring on the spindle, and push the bobbin down. Then push the bobbin winding spindle so that the latch fits into the bobbin. (Fig. 1)
- 3) Place a spool of thread on the spool pin.
- 4) Pass the thread between the discs of the tension bracket. (Fig. 3)
- 5) Pass the end of the thread through the hole in the bobbin from inside to outside. (Fig. 2)
- 6) Holding the thread with your right hand, turn the balance wheel to wind the thread several times. Then cut the free end of the thread.
- 7) Run the machine until the thread is wound sufficient for requirements in the bobbin and stop the machine. Then take out the bobbin from the spindle and cut the thread.
- 8) Tighten the stop motion screw.

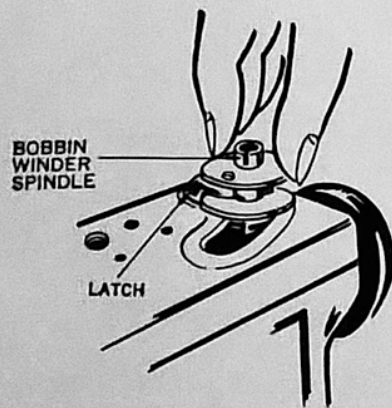

Fig. 1

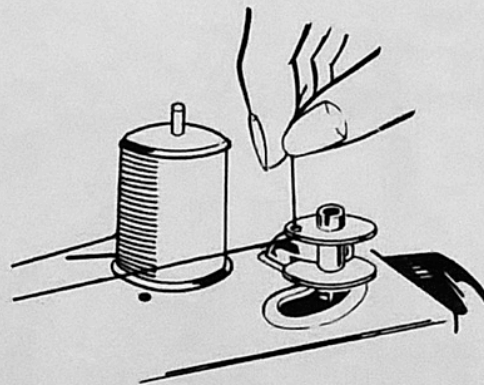

Fig. 2

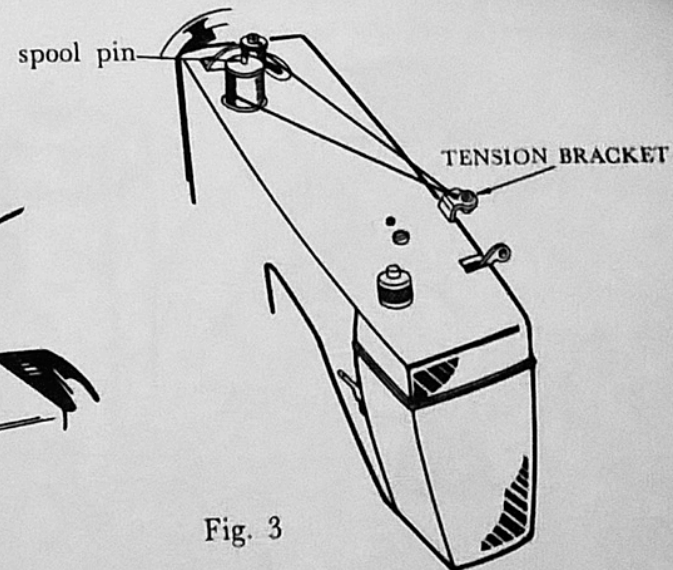

Fig. 3



### TO ADJUST BOBBIN WINDING DEVICE

The bobbin must be wound evenly. If not, irregular stitching will be the result. When the bobbin is wound excessively on the upper part of the bobbin (A), loosen the top cover thread guide set screw on the front of the top cover and lower the thread guide slightly. Tighten the screw to reset the thread guide.

When it is wound excessively on the lower part of the bobbin (B), loosen the thread guide set screw and raise the thread guide slightly. Tighten the screw to reset the thread guide.



A



B

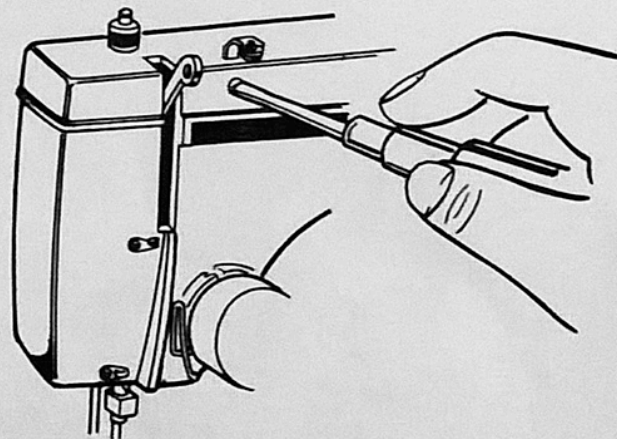

Correctly Wound

### TO THREAD BOBBIN CASE

Holding the bobbin case in your left hand, turn the side up and place the thread bobbin into it (Fig. 1).

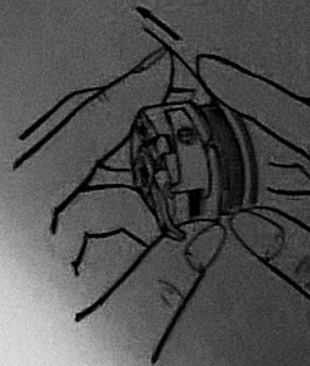

Fig. 1

### TO THREAD BOBBIN CASE

Holding the bobbin case in your left hand, turn the open side up and place the threaded bobbin into it (Fig. 1).

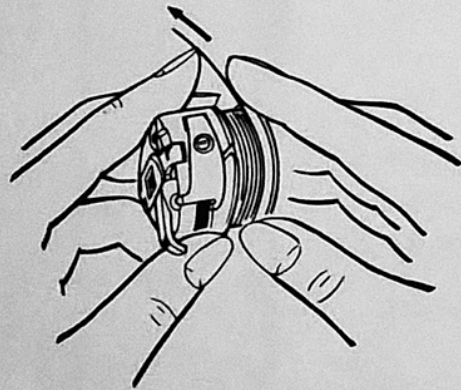

Fig. 1

Guide the thread into the slot in the edge of the bobbin case (Fig. 2).

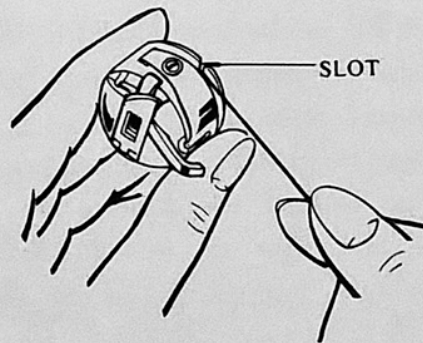

Fig. 2

Pull it under the tension spring and then into the delivery eye (Fig. 3).

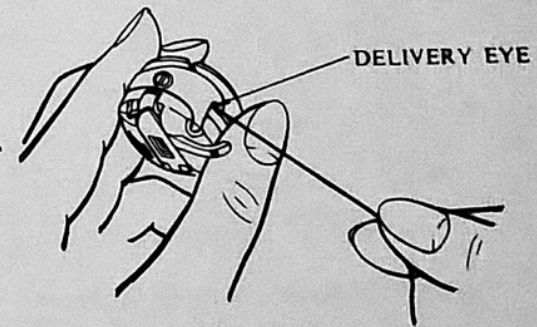

Fig. 3

### TO INSERT BOBBIN CASE INTO THE MACHINE

Raise the needle bar and take-up lever both to their highest point.

Open the slide plate.

Hold the bobbin case by the latch and place it on the centre post with the bobbin case finger in the notch at the top of the shuttle.

Release the latch and press the bobbin case into the shuttle until the latch catches on the centre post with a click.

Permit the thread to hang down freely a few inches.

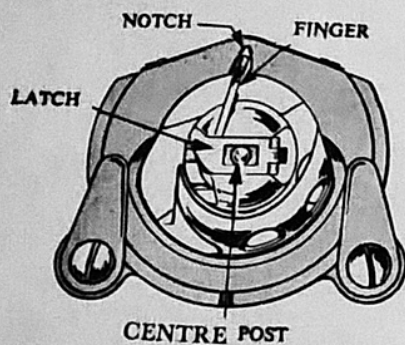

### TO INSERT NEEDLE

Raise the needle bar (A) to its highest point by turning the balance wheel with your right hand.

Loosen the needle clamp screw (B) at the end of the needle bar, and insert the needle (C), with the flat side to the right, into the slot of the needle bar.

Insert the needle as high as it will go until it touches the pin which is visible in the slot above the needle clamp and tighten the needle clamp screw firmly.

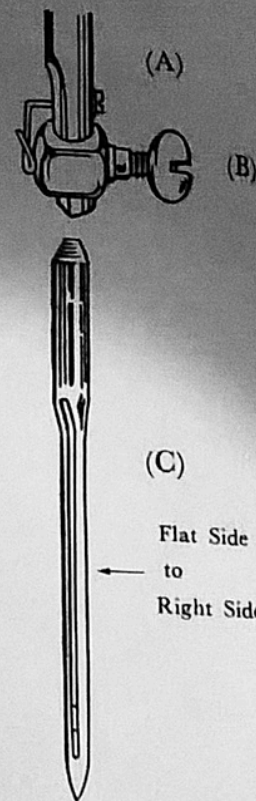

### RIGHT NEEDLE AND

Size of Needles

No. 9

No. 11

No. 14

No. 1

No.

NOTE: Use

**RIGHT NEEDLE AND THREAD FOR RIGHT CLOTH**

Size of Needles	C l o t h	Size of Threads
No. 9	Thin calico, silk, serge and muslin.	No.80-100 cotton thread or fine silk thread.
No. 11	Thin calico, cotton cloth, crepe de Chine, hosiery and silk.	No. 60-100 cotton thread or ordinary silk thread.
No. 14	Ordinary cotton cloth, thick silk, thin woolen goods, towels and shirting.	No. 40-60 cotton thread or ordinary silk thread.
No. 16	Thick cotton cloth, serge and thin woolen goods.	No. 30-60 cotton thread or ordinary silk thread.
No. 18	Ordinary woolen goods, trousers, over-coats, thick calico and children's clothes.	No. 30-60 cotton thread or ordinary silk thread.

**NOTE:** Use a good quality mercerized cotton thread, if available, to avoid shrinking when laundered.

### TO THREAD NEEDLE

Raise the take-up lever (5) to the highest point by turning the balance wheel toward you.

Place a spool of thread on the spool pin.

Pass the thread through upper arm thread guide (1), downwards around tension discs (2) from right to left, up over the tension thread guard (3) from behind, through the loop of the take-up spring (4), up and through the hole in the take-up lever (5), down through thread guides (6&7) and into the thread guide (8) at the lower end of the needle bar.

Then pass through the eye of the needle from left to right.  
Draw about two inches of thread through the eye of the needle.

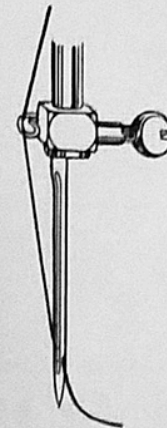
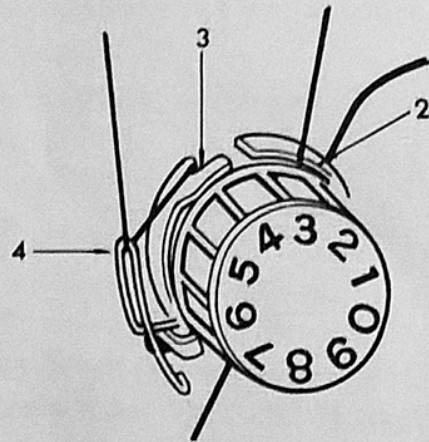
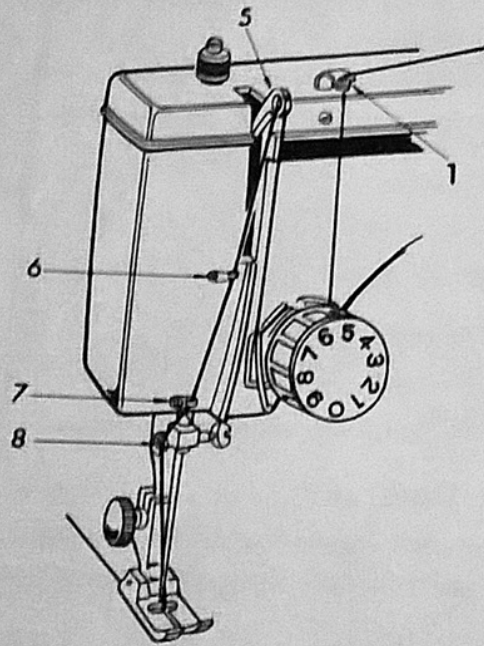

### TO RAISE LOWER THRE

Hold the upper thread t  
Turn the balance wheel  
until the needle and th  
and up again, both to  
balance wheel and pull  
up the lower thread th  
Place both ends of the

### TO START SEWING

Place the cloth und  
With the left hand  
turn the balance w  
penetrate the point  
Lower the presser

### **TO RAISE LOWER THREAD**

Hold the upper thread loosely with your left hand.  
Turn the balance wheel towards you with your right hand until the needle and the thread take-up lever move down and up again, both to their highest point, then stop the balance wheel and pull the upper thread slowly to bring up the lower thread through the needle hole.  
Place both ends of the threads back under the presser foot.

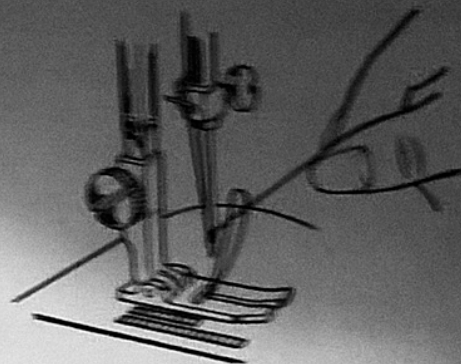

### **TO START SEWING**

Place the cloth under the presser foot.  
With the left hand hold loosely both ends of threads and turn the balance wheel by the right hand to let the needle penetrate the point from which to start sewing.  
Lower the presser foot on the cloth and start sewing.

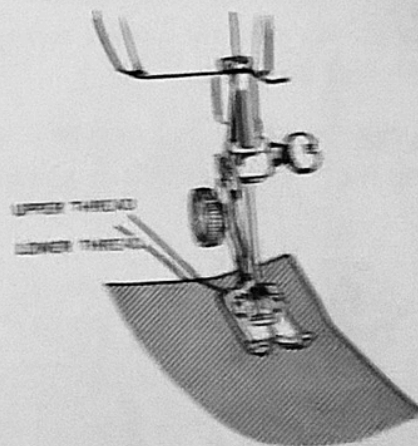

### TO REGULATE TENSION OF UPPER THREAD

For ordinary stitching the tension of the upper and lower threads should be set so as to lock both threads in the centre of the fabric. (A)

If the tension of the upper thread is too strong, the upper thread will lie straight along the upper surface of the fabric as shown in (B).

In such case, turn the thread tension dial knob anti-clockwise or to the smaller number.

If the tension of the upper thread is too weak, the lower thread will lie straight along the underside of the fabric as shown in (C). In such case turn the thread tension dial knob clockwise or to the larger number.

(Usually No. 5 on top will be found to be correct for straight sewing and No. 3 on top for zigzag sewing.)

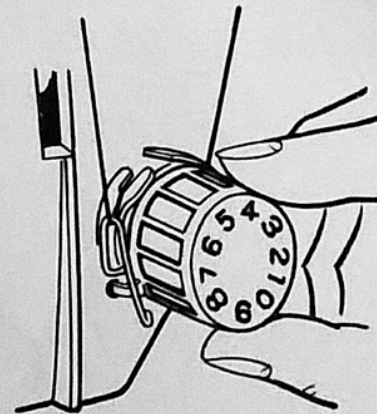
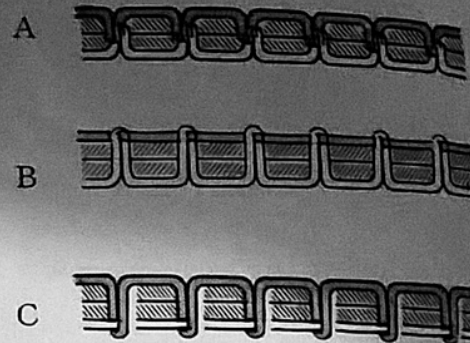

### TENSION OF LOWER

The tension of the  
on the bobbin case  
To increase the  
driver.

To decrease the

### TO USE BUILT-I

Sewlight is con  
machine when  
This results in  
is connected to  
To change the  
and turning i  
pins on the b  
it clockwise.

### **TENSION OF LOWER THREAD**

The tension of the lower thread is regulated by a small screw on the bobbin case tension spring.

To increase the tension, tighten the screw slightly with a small driver.

To decrease the tension, loosen the screw slightly.

### **TO USE BUILT-IN SEWLIGHT**

Sewlight is connected directly to the main supply lead of the machine when the motor plug is inserted into the connector. This results in the light acting as a warning when the machine is connected to the electricity supply.

To change the bulb, remove same by slightly pushing it upward and turning it anti-clockwise. Insert a new bulb by fitting the pins on the bulb into the slot, pushing upwards and turning it clockwise.

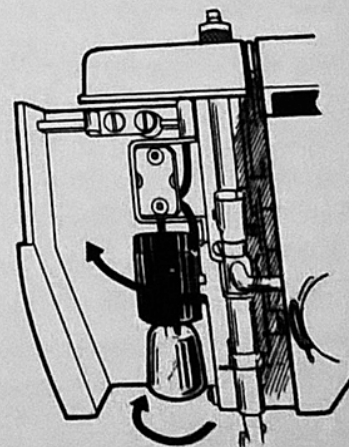
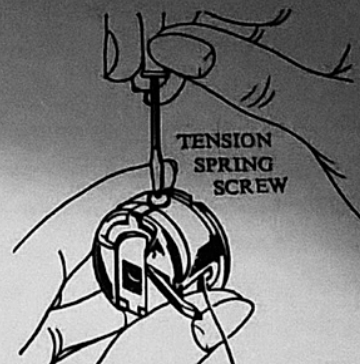



### TO ADJUST PRESSURE ON PRESSER FOOT

For releasing pressure on the foot, press down the ring (A), which will allow the pressure regulator to spring up to its highest position and leave the material free from any pressure from the presser foot. For sewing thin or light fabrics, press the top of the pressure regulator (B) down lightly to get the required slight pressure of the fabric. For sewing thicker or heavier fabrics, push the top of the pressure regulator down further, in order to get a stronger pressure on the presser foot.

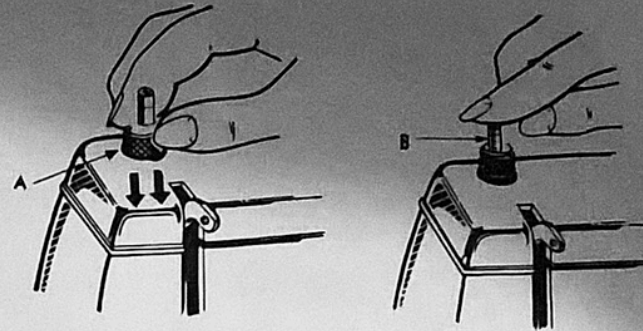

### TO USE DROP FEED DEVICE

Darning and embroidering is facilitated by means of the drop feed knob (1) on the right hand corner of the bed.

When this knob is set at "EMBR", the feed teeth (2) drop below the surface of the needle plate so that it will not interfere with the free movement of the cloth.

The feed teeth will return and resume their normal operation when the knob is set at "NORM".

For sewing light materials like silk, it may be set at "SILK" position in order to avoid puckering the material.

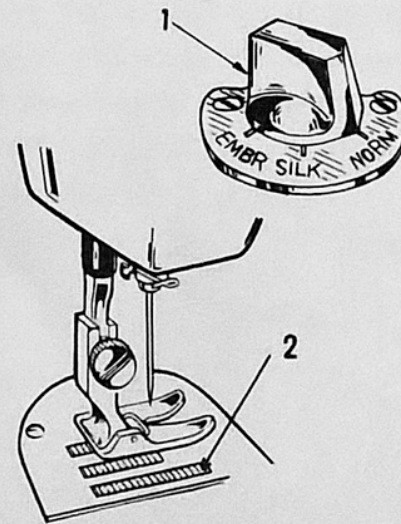

### TO REGULAT

To regulate  
stitch length  
required sti  
window (2)  
For straight  
control kn  
go.  
It is advi  
straight se  
accessories.

### TO REGULATE LENGTH OF STITCH AND DIRECTION OF FEED

To regulate the length of stitch, turn the stitch length regulator knob (1) to show the required stitch length in the stitch indicator window (2).

For straight sewing, move the zigzag width control knob (3) to the right as far as it will go.

It is advisable to use the presser foot for straight sewing (5) which is included in the accessories.

For reverse stitching, first adjust the stitch length control knob (1) to obtain the desired stitch length and then push in the reverse button (4) as far as it will go.

Machine will sew in reverse as long as the reverse push button is held in.

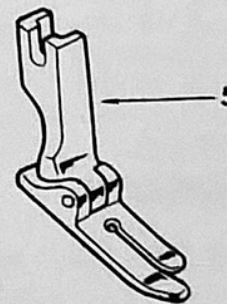
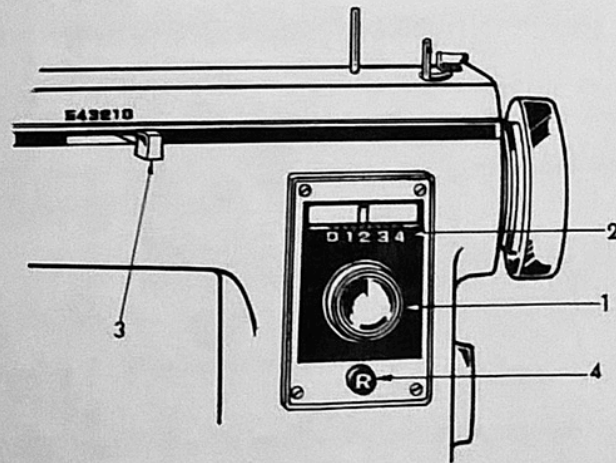

## STRAIGHT SEWING AND ZIGZAG SEWING

For straight sewing, set the zigzag width control knob at "0".

Make sure the presser foot is for straight sewing.

For zigzag sewing, make sure the presser foot is for zigzag use.

Zigzag stitch is controlled by the zigzag width control knob on the arm of this machine.

By moving this control knob gradually to the left toward "5", the machine will sew a zigzag seam of increasing width depending on the position of the control knob.

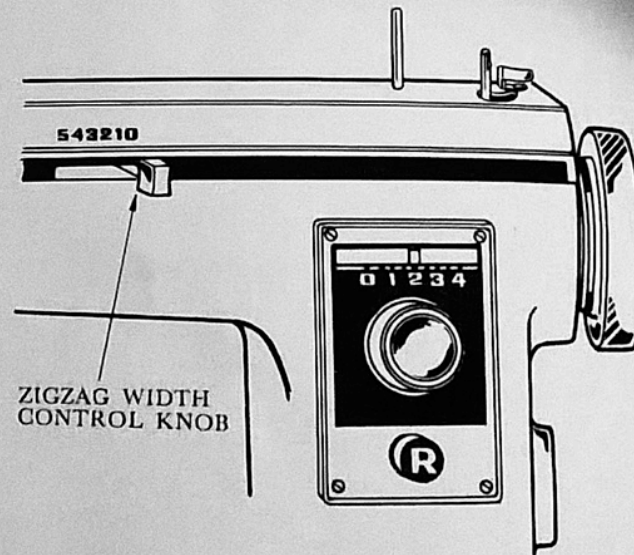
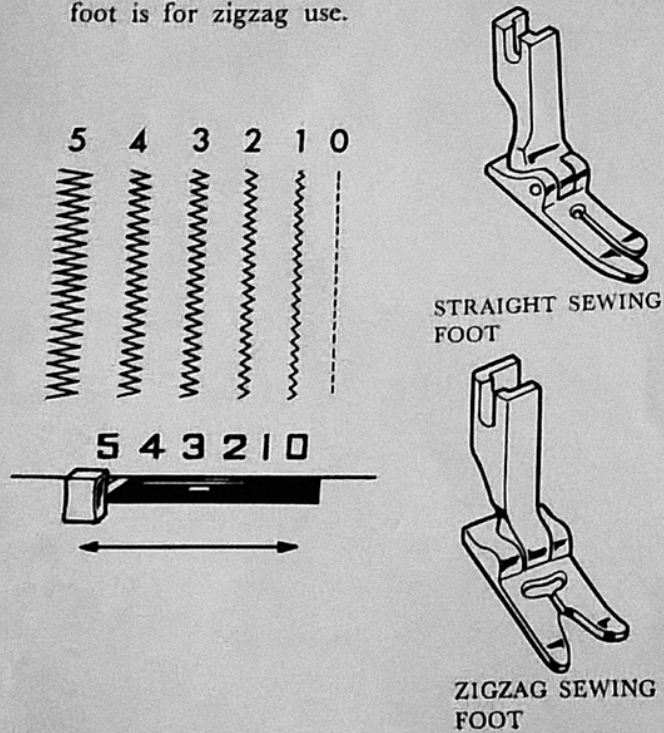

## MANUAL ZIGZAG

By manually adjusting the zigzag width control knob, you can create various ornamental stitches.

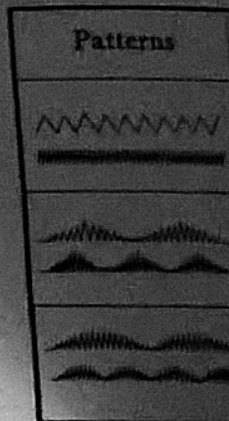







## TO REMOVE

Raise the needle and foot to the top position.

Leave the needle and foot in the top position.

## MANUAL ZIGZAG PATTERN SEWING

By manually adjusting the stitch length and zigzag width while running the machine, some beautiful ornamental stitches can be made as follows:

Patterns	Stitch Length	Width	Patterns	Stitch Length	Width
	long short	Set to any point from 1 to 5.		long and short (repeat)	Set to any point from 0 to 5.
	long short	Gradually move the lever from 0 to 5 and return to 0. (repeat)		long short	Set to 0. Quickly move the lever to 5 and back to 0. (repeat)
	long short	Very slowly move the lever from 0 to 5 and return to 0. Gradually move the lever from 0 to 5 and return to 0. (repeat)		long short	Move the lever quickly and alternatively from 2 to 5 and from 5 to 2.

### TO REMOVE WORK

Raise the needle bar to its highest point, lift the presser foot, draw the fabric back and cut the ends of threads.

Leave the machine threads about four inches long to resume sewing.

## BUTTONHOLE SEWING

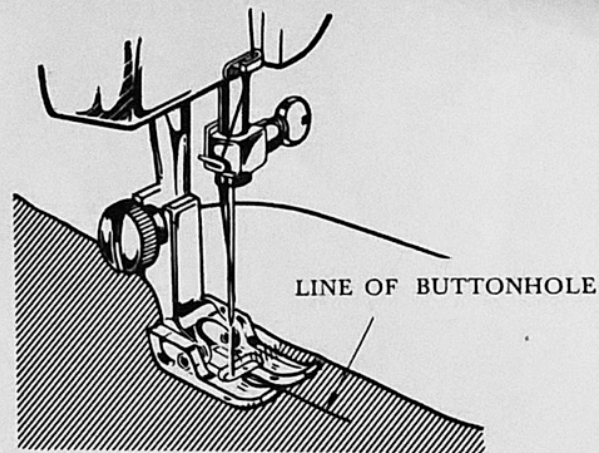

1. Remove the regular presser foot and attach the buttonhole foot.
2. Set the zigzag width knob between "1" and "2".  
Set the stitch length regulator knob to obtain close stitches (satin stitch).
3. Mark with a pencil or chalk the position and exact length of the buttonhole on the fabric.

4. Lower th  
Lower th  
of the m  
Stop the
5. Lift the  
to posit
6. Raise n
7. Set the
8. Raise v
9. Now t  
and "  
shown
10. To m
11. Retur
12. Remi

4. Lower the needle carefully into the mark on the fabric indicating the beginning of buttonhole. Lower the presser foot and commence sewing the left row of the buttonhole until it reaches the end of the marking. (1)  
Stop the machine with needle on fabric at point A.
5. Lift the presser foot and using the needle as a pivot, turn the fabric end for end to bring the buttonhole to position (2).
6. Raise needle from fabric and drop the feed teeth by setting the drop feed knob at "EMBR".
7. Set the zigzag width control knob at "4" and sew three or four stitches to make bar-tack. (2)
8. Raise needle from fabric, also raise feed teeth by setting the drop feed knob at "NORM".
9. Now to sew the other row of the buttonhole, return the zigzag width control knob between "1" and "2" (to its original setting) and commence to sew until your stitching reaches the position shown in figure (3).
10. To make the final bar-tack, again setting the drop feed knob at "EMBR" and sew the bar-tack. (4)
11. Return zigzag width to "0" and take two or three stitches to fasten bar threads and prevent ravelling.
12. Remove fabric from the machine and open the buttonhole with a buttonhole cutter or seam ripper.

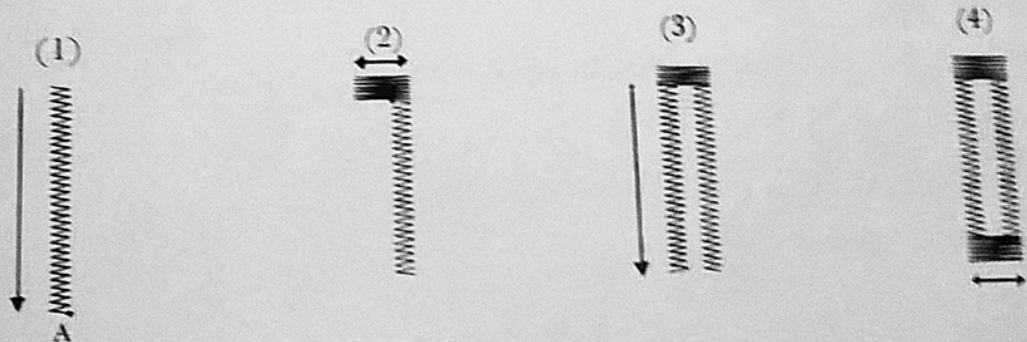

on the fabric.

### **BUTTON SEWING**

Fit the button sewing foot to the machine. Set the drop feed button at "EMBR." With the button sewing foot in a raised position, place a button on the fabric with its holes in a horizontal line and the left side hole underneath the needle, and lower the foot upon it.

Set the zigzag width control knob in accordance with the distance between the holes in the button, so that the needle enters the right side hole.

Sew six or seven stitches by turning the balance wheel with your right hand.

To lock the thread, set the zigzag width control knob at "0" and make three or four stitches.

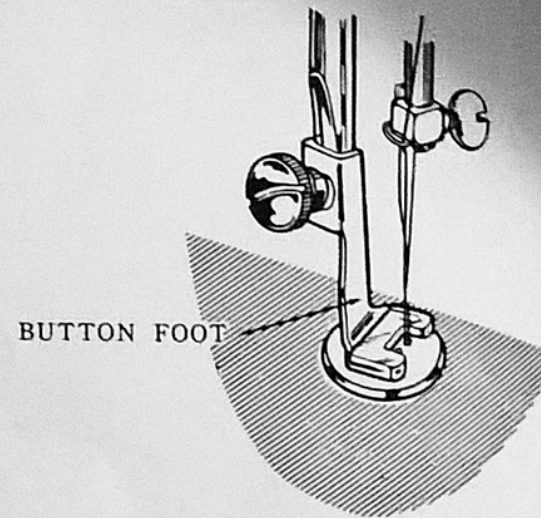

### **EMBROIDERY**

Raise the pres  
thread tension  
Set the drop  
Now your m  
Embroidery  
Hold the ho  
in the vicia  
This will be  
Manipulate  
Adjust thr  
thread tens

## EMBROIDERY

Raise the presser bar lifter and remove the presser foot. Then lower the presser bar lifter to ensure the thread tension device is set correctly.

Set the drop food knob at "EMBR".

Now your machine is ready for embroidery.

Embroidery will be done most successfully when the fabric is stretched and fixed in an embroidery hoop.

Hold the hoop closely on the machine bed with both hands, press the material with your left forefinger in the vicinity of the needle.

This will help in holding down the material and will prevent the machine from making skipped stitches.

Manipulate work carefully and be sure to keep fingers out of the path of the needle.

Adjust thread tensions for the best appearance of embroidery work and slightly increase the bobbin thread tension to avoid the lower thread from being pulled up.

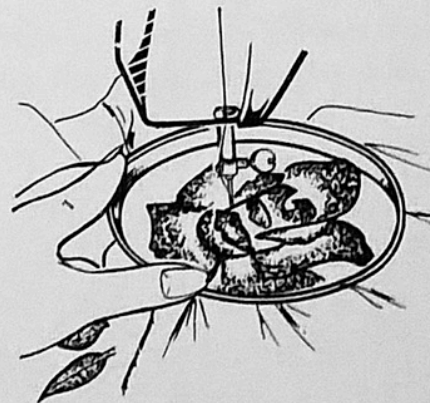
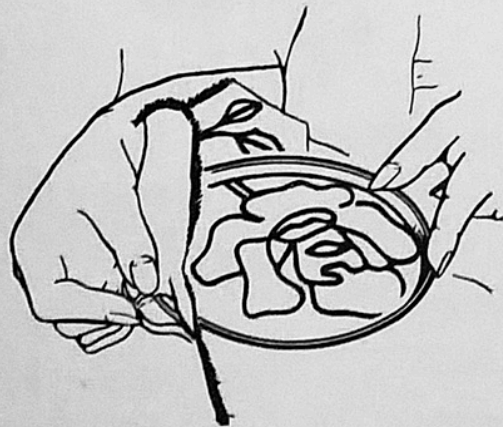



## HEMMING

Raise the needle to its highest point.

Raise the presser bar, remove the regular presser foot, and attach a hemmer foot.

Fold over the edge of the fabric approximately  $\frac{1}{8}$  inch wide, then fold it over again in the same way for a length of about 2 inches.

Insert this folded end into the spiral-formed opening (scroll) of the hemmer foot.

Move the fabric back and forth until the hem forms itself in the scroll.

Pull the fabric toward you until the beginning of the hem is just below the needle.

Guide the fabric into the hemmer foot while proceeding.

Note : Do not crowd fabric into the scroll, nor leave the scroll only partly filled with fabric.

Instead of a straight stitch, you can also use a zigzag stitch for this hemming operation.

Be sure, however, to adjust the width of the zigzag stitch so that it is as wide as the hem itself.

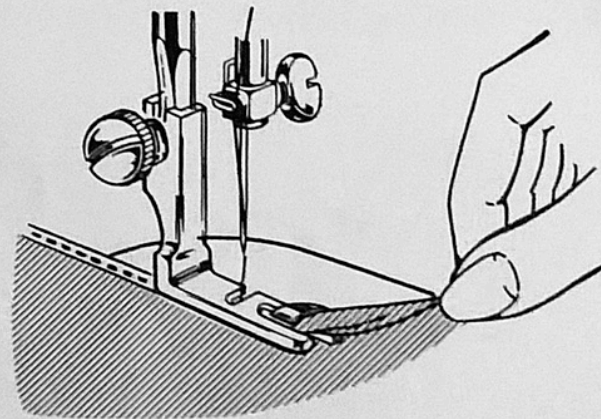

First open  
the posit

Set the

Loosen  
the left  
zipper

To sew  
to the

the same

### SEWING IN A ZIPPER

The zipper foot included in the accessories enables you to attach a zipper on fabric.

Remove the regular presser foot and attach the zipper foot to the presser bar of the machine.

First open out the zipper and place fabric in the position under the needle.

Set the machine for straight stitching.

Loosen the thumb screw (A) to set the foot on the left side of the needle and sew the left-side zipper as shown.

To sew the right-side zipper, bring the foot to the right side of the needle

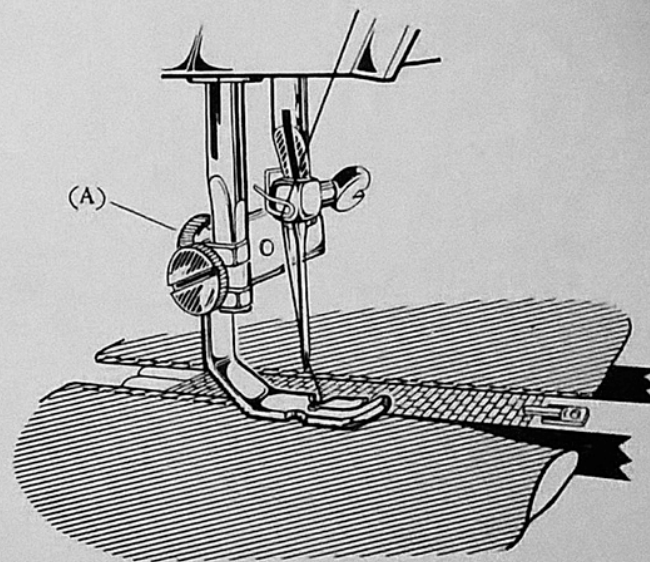

### **BLIND STITCH HEM**

With the fabric inside out, fold it to the desired size of the hem. (No. 1)

Fold it again with a 1/4 inch overlap on the bottom fold. (No. 2)

Set the zigzag width control knob at "3" and the stitch length regulator knob at about "2", and sew on the fold. (No. 3)

Then unfold the fabric, and you will have a blind stitch hem. (No. 4)

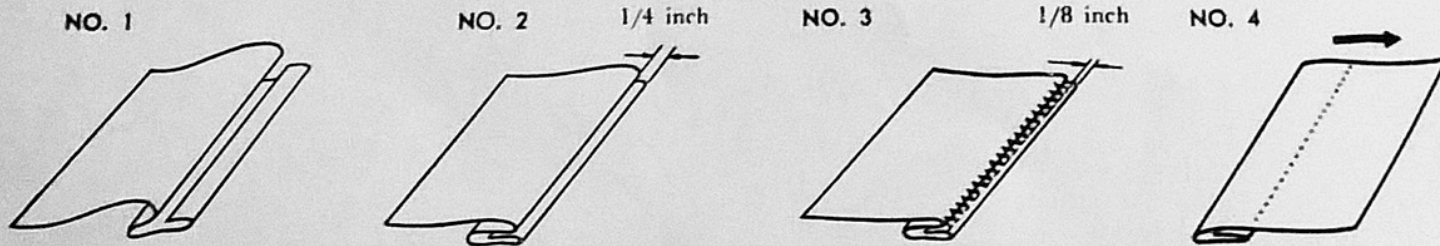

TO CLEAN S

Because your  
shuttle thread  
shuttle, it w  
shuttle-race.

However, if  
to open an  
to do this  
the precise  
of the ma

To open  
highest p

Next, tw  
take out

Carefully  
Replace  
clasps.

Be care

## TO CLEAN SHUTTLE RACE

Because your machine is specially equipped with the shuttle thread ejector which prevents jamming of the shuttle, it will rarely be necessary to open and clean the shuttle-race.

However, if for some reason it should ever be required to open and clean the shuttle-race, its design enables you to do this most easily and conveniently without sacrificing the precise fit which is so essential to the efficient working of the machine.

To open the shuttle-race, first raise the needle bar to its highest point and remove the bobbin case.

Next, twist the shuttle-race ring clasps outward and take out the shuttle ring.

Carefully remove shuttle hook and clean out shuttle-race. Replace shuttle hook, shuttle-race ring and lock with clasps.

Be careful not to drop or otherwise damage the shuttle.

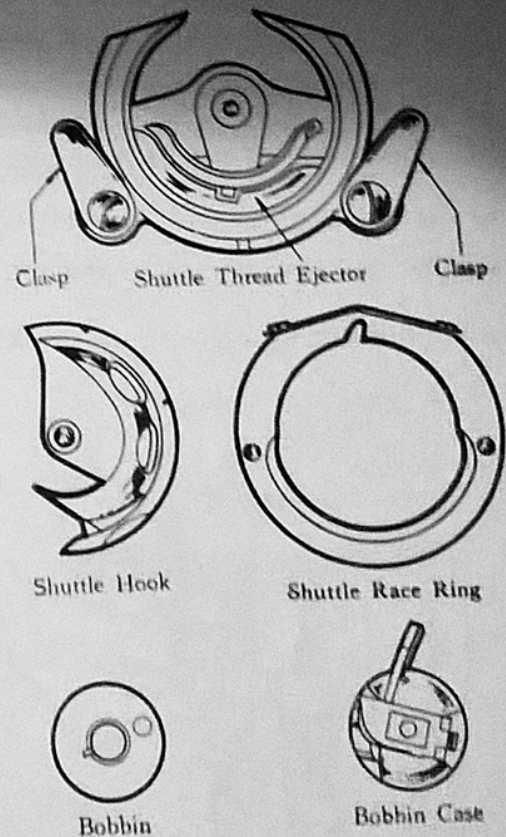

## TO OIL MACHINE

Apply a few drops of fine quality sewing machine oil to the points indicated by the arrows in the figures.

In constant use, oil two or three times a week.

In case the machine does not work smoothly due to standing idle for some time, apply a few drops of paraffin at the oiling points, and run the machine rapidly for a minute.

Before lubricating, wipe off the oiling points.

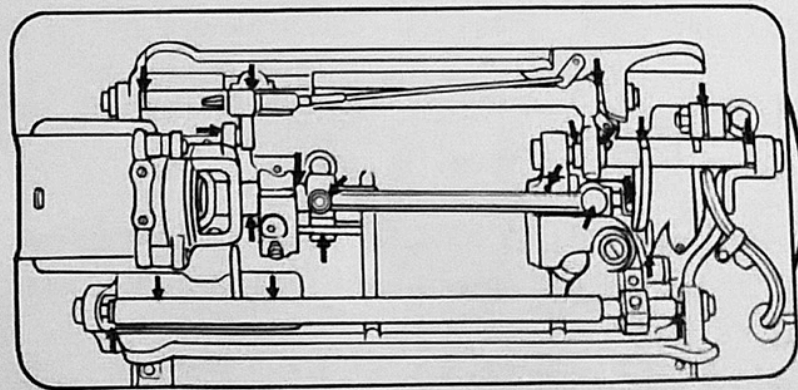
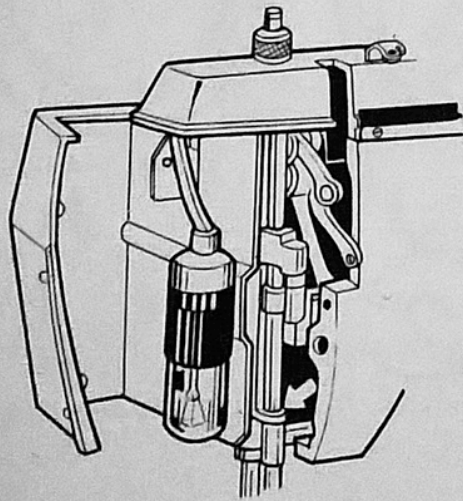

CARE AND

1) ATTACH

Place  
on the  
brack  
Then  
the r  
the s

## CARE AND ADJUSTMENT OF MOTOR

### 1) ATTACHING THE MOTOR TO THE MACHINE

Place the motor bracket (A) on the boss (B) on the arm, with which the slot in the motor bracket fits.

Then insert the screw (C), and after shifting the motor upward as far as it will go, tighten the screw. (Fig. 1)

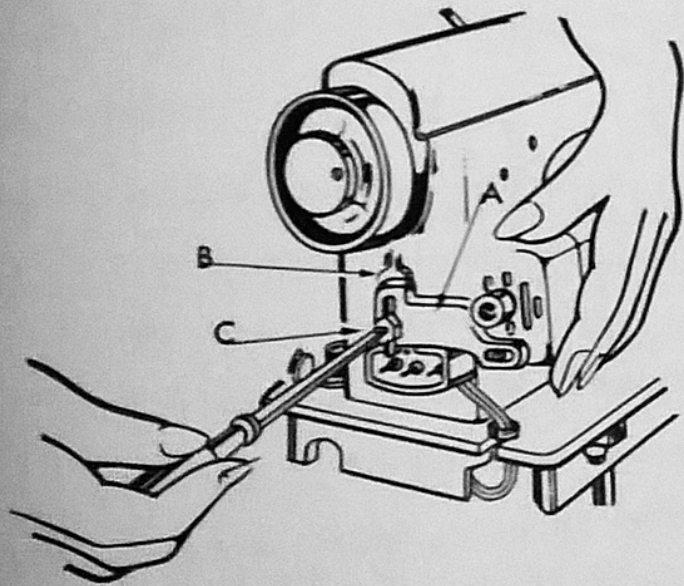

Fig. 1

### 2) PLACING THE BELT ON THE MOTOR

Slip the belt into the groove in the balance wheel, and force it into the groove in the motor pulley. (Fig. 2)

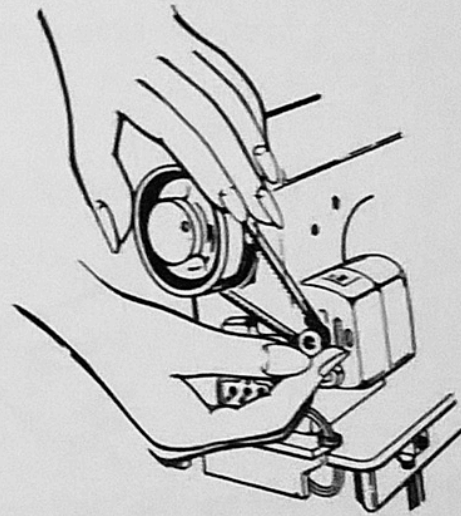

Fig. 2

### 3) REGULATING THE BELT TENSION ON THE MOTOR

To adjust the belt tension, loosen the attaching screw about one turn with a screwdriver.

This will allow the motor to drop downward.

Then firmly tighten the screw, and the belt should have the correct tension.

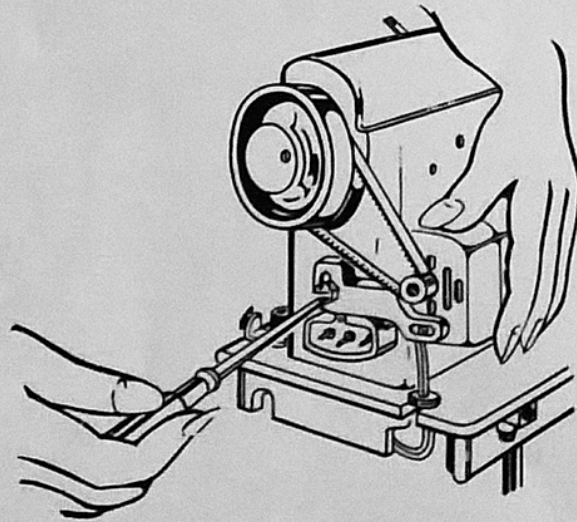

SUGGEST

Machin

See if t

so, clea

If the

Then

The u

Threo

If the

If t

case

## **SUGGESTIONS FOR SMOOTH SEWING**

### **Machine Working Heavily**

See if the shuttle race, feed dog and underneath parts of the needle plate are clogged with lint. If so, clean out the part.

If the machine works hard after standing for some time, apply a little paraffin in place of oil.

Then run the machine rapidly to clean the bearings, and oil the machine with sewing machine oil.

The use of inferior oil is usually the cause of the machine working heavily.

### **Thread Breaks**

If the needle thread breaks, it is probably due to one of the following causes:

The machine being improperly threaded.

The tensions being too tight.

The needle being bent or having a blunt point.

The thread take-up spring broken.

If the lower thread breaks, adjust the bobbin thread tension; also see that the inside of the bobbin case and the underneath part of the tension spring are free from lint.



## ***SUGGESTIONS FOR SMOOTH SEWING***

### **Skipped Stitches**

A bent or blunt pointed needle is often the cause of this. See that the needle is accurately inserted. Remove the needle plate, and, after ascertaining that the feed is clean and working freely, reset the needle plate.

### **Needle Breaks**

See that the needle is not bent and avoid pulling the material when stitching; either condition will cause the needle to strike on the needle plate and break.

### **Material Puckers**

This is generally due to incorrect tension. See that both the bobbin case and the needle are properly threaded; that the thread used is of good quality and the correct size for the needle.

### **Stitches Loop**

This is regulated by the tensions. See that both the bobbin case and the needle are properly threaded; that the thread used is of good quality and the correct size for the needle.